

[CONTRIBUTION NO. 618 FROM THE DEPARTMENT OF CHEMISTRY, INDIANA UNIVERSITY]

## The Surface Tensions and their Temperature Coefficients of Molten Mixtures of Potassium Chloride and Barium Chloride

BY JOHN S. PEAKE AND MARVIN R. BOTHWELL<sup>1</sup>

RECEIVED AUGUST 19, 1953

Measurements of the surface tensions of molten salt mixtures within the potassium chloride-barium chloride binary system show for each composition the usual substantially linear variation with temperature. The surface tension values at constant temperature do not show a linear variation with mole fraction but have a definite curvature. Apparatus design and experimental techniques are discussed in this paper.

### Introduction

Data on the surface tensions of multi-component mixtures of molten salts are not plentiful in the literature in spite of the importance of such mixtures in technological applications. Measurements of this property should have practical as well as theoretical interest. Surface tensions and related interfacial tensions are of particular importance in such metallurgical operations as welding and soldering which depend upon the solvent and surface tension properties of molten saline fluxes. In magnesium technology, for example, molten salts are required to effect coalescence of the globules of metal in the electrolytic cells as well as in founding operations. For the latter application it has been common practice to use salt mixtures belonging to the system potassium chloride-magnesium chloride-barium chloride.

The present investigation was undertaken as a beginning to the study of this system but was limited to measurements on the potassium chloride-barium chloride binary. The melts belonging to this system are stable in air and do not involve the complications encountered with melts containing magnesium chloride, for barium chloride has no tendency to hydrolyze or to react with atmospheric oxygen to form free chlorine. Open crucibles can therefore be used when making measurements on these mixtures.

The methods available for the measurement of the surface tensions of molten salts are few. The method of measuring the maximum pressure developed in static bubbles formed on the end of a capillary tip immersed in the melt under investigation is the best to apply to the study of liquids in this temperature range. This method has the distinct advantage of involving no empirical factors, since surface tensions may be calculated simply from readily measured dimensions. The other methods of surface tension measurement commonly employed at ordinary temperatures fail for various reasons at the high temperatures involved when working with molten salts. These substances readily attack silica apparatus and many types of metal apparatus. The capillary rise method is thus impossible of application with salts melting above 800°. By using the maximum bubble pressure technique such difficulties can be eliminated, and the zone to be thermostated can be made quite small. It is thus easier to obtain a uniform temperature throughout the whole volume of material

(1) Taken from a portion of a thesis submitted by Marvin R. Bothwell to the Graduate School of Indiana University in partial fulfillment of the requirements for the degree of Doctor of Philosophy.

being investigated. Jaeger<sup>2</sup> has used this method with success up to temperatures as high as 1600°. Platinum alloys, preferably alloys of platinum with rhodium, can be used for constructing the bubble tip and, if necessary, the crucible or cell can likewise be constructed of these alloys. The melts required for such measurements can be reasonably small and can be contained in a No. 0 porcelain crucible. The contact surface between the melt and the bubble tip remains clean due to the absence of corrosion under controlled conditions. By the use of proper technique a flat end can be machined on the bubble tip, and by using jewellers' broaches an accurately round capillary can be reamed in the platinum alloy tube.

A critical discussion of the theory and methods of making surface tension measurements has been given by Harkins.<sup>3</sup> The maximum bubble pressure methods may employ either a single capillary tube or two capillary tubes of different bore as in the method of Sugden.<sup>4</sup> In our investigation we chose to employ a single tube. T. F. Young and his students<sup>5,6</sup> have made a careful study of the pattern formed by static bubbles on the end of a capillary tip. They have found that if the bubble is allowed to develop very gradually, its form corresponds to that of a static bubble, and the maximum pressure can be measured accurately. From this measurement and by employing the equation of Schroedinger,<sup>7</sup> one can calculate the surface tension of the melt.

$$\gamma = \frac{pr}{2} \left[ 1 - \frac{2r}{3h} - \frac{1}{6} \left( \frac{r}{h} \right)^2 \dots \right] \quad (1)$$

In the above equation

- $\gamma$  = surface tension of the melt
- $p$  = maximum pressure difference between the inside and outside of the bubble at the face of the tip
- $r$  = radius of the capillary at the tip
- $h$  =  $p/(\rho - \rho')g$  = height the manometer would read if filled with the liquid whose surface tension is being measured
- $\rho$  = density of the liquid being measured
- $\rho'$  = density of the gas
- $g$  = acceleration due to gravity

(2) F. M. Jaeger, "Optical Activity and High Temperature Measurements," McGraw-Hill Book Co., Inc., New York, N. Y., 1930, pp. 252-277.

(3) W. D. Harkins, in "Physical Methods of Organic Chemistry," Part I, 2nd ed., A. Weissberger, Editor, Interscience Publishers, New York, N. Y., 1949, pp. 355-425.

(4) S. Sugden, *J. Chem. Soc.*, **121**, 858 (1922); **125**, 29 (1924).

(5) M. Hoffman, "Pressure as a Function of the Shapes of Liquid Surfaces," M.S. Thesis, University of Chicago, 1926.

(6) H. P. Tripp, "Maximum Bubble Pressure Method for Measurement of Surface Tension," Ph.D. thesis, University of Chicago, 1931.

(7) E. Schroedinger, *Ann. Physik*, **46**, 410 (1915).

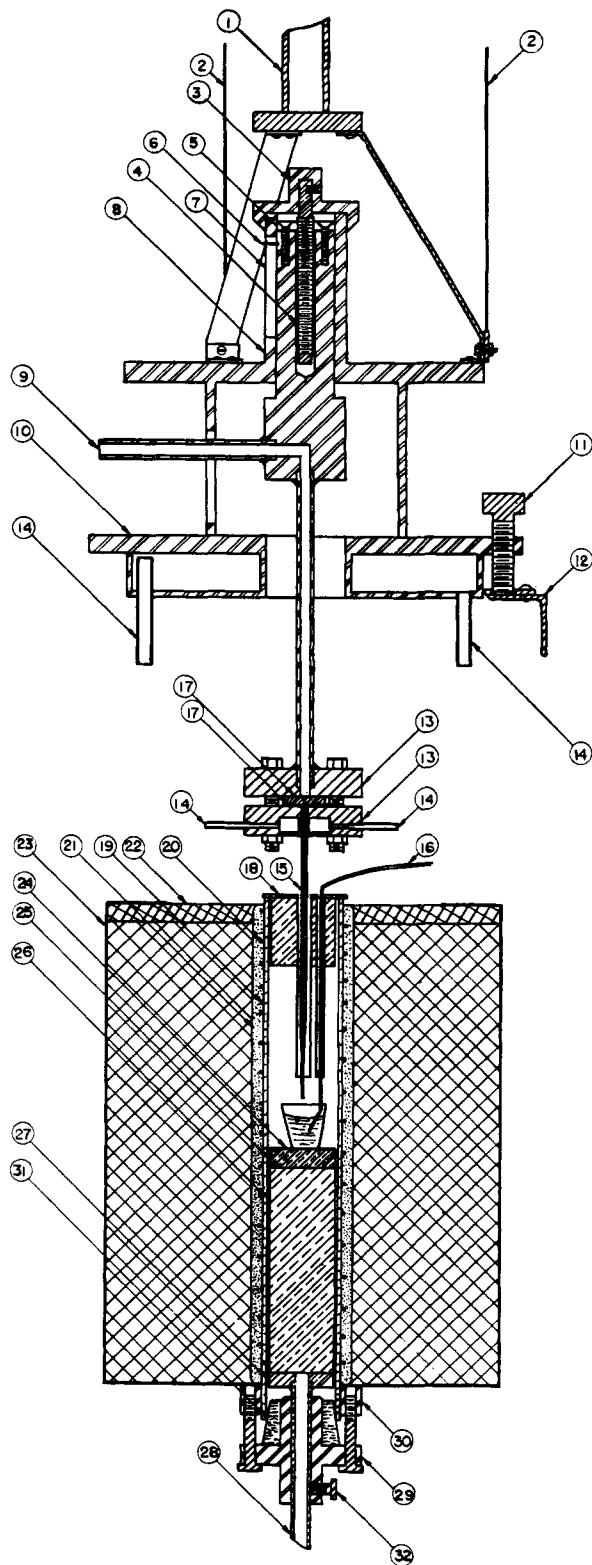

Fig. 1.—1, vertical guide shaft; 2, counterweight cable; 3, micrometer dial; 4, micrometer screw; 5, micrometer drive nut; 6, vertical scale pointer; 7, vertical scale; 8, micrometer guide sleeve and supporting bracket; 9, line to nitrogen supply, manometer, and micro pressure adjusting device; 10, combination leveling plate and radiation shield; 11, leveling screw; 12, angle-iron support; 13, bubble-tip

flanges; 14, cooling water inlet or outlet; 15, platinum bubble-tip; 16, thermocouple wires; 17, rubber-impregnated asbestos gaskets; 18, insulating brick radiation baffle; 19, silica furnace tube; 20, furnace windings; 21, alundum cement; 22, asbestos cement; 23, furnace shell; 24, porcelain crucible support; 25, high-alumina fire-brick; 26, insulating fire-brick; 27, stainless steel crucible lifter; 28, air inlet and plunger for lifting crucible; 29, plunger guide sleeve; 30, lock ring for furnace tube; 31, rubber stopper; 32, plunger lock screw.

### Experimental

**Preparation of Salt Mixtures.**—The melts used in the present investigation were prepared in the same manner as those for the density measurements described in the previous paper. The reader is referred to that paper for details on their preparation and analysis.

**Description of Apparatus.**—The essential details of the apparatus used in making surface tension measurements are shown in Fig. 1 and its accompanying legend. The complete apparatus shown in this figure was supported in a stand (not shown) having three vertical columns of one-inch steel pipe and three triangular platforms which could be adjusted vertically. The top platform supported a guide tube for maintaining vertical alignment of the guide shaft (1). It also supported three pulleys over which passed the cables (2) which connected the plate serving as a micrometer screw support with counterweights (not shown). The micrometer screw (4) in turn supported the capillary tip assembly. The combined leveling plate and radiation shield (10) rested on the central platform (12) of the pipe stand, while the furnace shell (23) rested on the bottom platform. The guide shaft (1) mentioned above served to prevent undue tipping of the plate attached to the counterweights. It also served as a means of clamping the whole assembly well above the normal operating position whenever the tip was being serviced or the crucibles containing the melts were put into the furnace. The nitrogen and manometer system shown schematically in Fig. 2 was connected to a tube (9) in the capillary support by means of flexible copper tubing which was suitably coiled to provide adequate freedom of vertical movement of the capillary tip assembly. The manometer was filled with dibutyl phthalate and was thermostated. The micro pressure adjusting device (6), in Fig. 2, was a special vise which would be very slowly adjusted by turning a worm and worm gear assembly. This clamped down on a plastic tube filled with mercury and made it possible to displace nitrogen into the system very slowly.

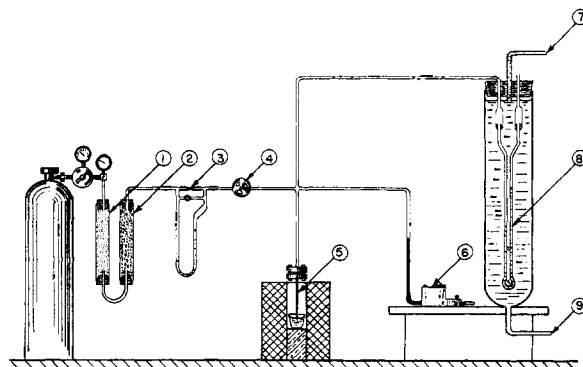

Fig. 2.—Schematic diagram of nitrogen system: 1, tube filled with Ascarite; 2, tube filled with phosphorus pentoxide on asbestos; 3, capillary flow meter with by-pass; 4, refrigeration check valve; 5, platinum bubble-tip; 6, micro pressure adjusting device; 7, thermostat water outlet; 8, manometer; 9, thermostat water inlet.

The capillary tube or bubble tip (15) shown in Fig. 1 was made of a 90% Pt-10% Rh alloy and had a flange on its upper end. This flange being clamped between rubber gaskets which were in turn clamped between the bolted flanges (13) served as the means of connecting the bubble

TABLE I  
 SURFACE TENSIONS OF KCl-BaCl<sub>2</sub> MIXTURES<sup>a</sup> (IN DYNES PER CENTIMETER)

0% BaCl <sub>2</sub> T	γ	3.9% BaCl <sub>2</sub> T	γ	8.4% BaCl <sub>2</sub> T	γ	13.5% BaCl <sub>2</sub> T	γ	24.4% BaCl <sub>2</sub> T	γ	29.4% BaCl <sub>2</sub> T	γ	34.0% BaCl <sub>2</sub> T	γ
830	94.0	817	96.9	813	98.9	820	101.0	810	109.0	815	109.2	804	112.0
834	93.7	818	97.0	832	98.2	828	100.5	832	107.0	830	109.0	830	111.0
844	93.4	840	95.0	843	98.4	845	100.5	857	105.0	845	107.8	850	109.8
848	92.8	848	94.2	859	97.1	860	98.6	864	104.8	854	107.5	859	109.1
850	92.8	850	94.5	869	96.4	874	97.8	874	104.2	870	106.9	872	108.5
858	91.8	858	92.8	875	96.1	882	96.8	887	103.9	882	106.4	882	107.8
866	91.7	865	93.7	878	95.0	890	96.1	894	103.2	888	105.5	894	106.6
868	91.2	875	92.5	888	94.8					898	104.8		
869	90.8	879	92.5	891	94.6								
878	90.5	890	91.3										
880	90.6	902	90.4										
892	89.8												
919	87.9												

37.3% BaCl <sub>2</sub> T	γ	42.3% BaCl <sub>2</sub> T	γ	47.7% BaCl <sub>2</sub> T	γ	62.3% BaCl <sub>2</sub> T	γ	82.1% BaCl <sub>2</sub> T	γ	100% BaCl <sub>2</sub> T	γ
820	113.1	819	115.9	819	120.3	852	128.8	904	143.5	981	164.1
834	112.1	834	115.0	833	117.8	883	127.1	907	144.0	985	163.6
843	111.4	840	114.5	843	117.2	896	128.2	923	142.6	988	163.8
850	111.6	856	114.0	862	117.3	928	123.2	927	142.2	1004	161.7
858	110.8	865	112.9	870	116.6	929	123.3	958	140.4	1006	162.0
864	110.2	875	113.4	878	116.5	956	120.3	959	139.9	1026	160.6
883	109.3	886	112.7	890	115.6	959	120.9	991	136.9	1027	160.1
890	108.0	900	111.6							1041	159.5

<sup>a</sup> All percentages are mole per cent. All temperatures in °C.

tip to the nitrogen system and of supporting it rigidly. Such an arrangement made it easy to remove the bubble tip for periodic inspection and servicing.

A Pt vs. Pt-10% Rh thermocouple (16) was immersed in the melt for making temperature measurements, inasmuch as the couple did not interfere with the use of the bubble tip as it would have interfered with the sinker of the density apparatus of the previous paper. The temperature was determined from e.m.f. measurements using this thermocouple connected to a similar one kept in an ice-bath. The e.m.f. generated by these couples was read accurately with a Type K Leeds-Northrup potentiometer connected to a sensitive galvanometer. Other details will be evident from the figures.

**Experimental Procedure.**—Before making measurements of the surface tensions of molten salts using this technique, the bubble tip must be carefully prepared. Furthermore, during use it must be checked periodically to detect any imperfections arising from corrosion or damage due to mechanical causes. Our tip had a bore at the end of the capillary of slightly less than 0.5 mm. This required special equipment for ensuring that the end of the tube was machined flat, smooth, and perpendicular to the axis of the capillary. The bore of the capillary had to be made accurately round near the tip. Its diameter was determined by measuring the diameter of the hole formed by the intersection of the capillary with the perpendicular plane machined on the end of the tip. This was accomplished by mounting the capillary tube in a suitable jig attached to a microscope in a manner such that the axis of the capillary coincided with the optic axis of the microscope. A filar micrometer eyepiece calibrated for use with this microscope served as the measuring means. The diameter of the opening was measured at intervals of thirty degrees and in both senses, taking the average of twenty-four such readings as the diameter of the opening. Such care was justified by virtue of the direct proportionality between the surface tension and the radius of this opening, as seen from equation 1.

The salt mixture to be investigated was placed in a porcelain crucible and then melted in the furnace. In order to maintain a mildly oxidizing atmosphere at all times, thus preventing attack by carbonaceous gases upon the platinum alloy tip and thermocouple, dry air was passed into the furnace at the bottom. The thermostat for the manometer was then put into operation. A slow flow of dry nitrogen was passed through the nitrogen system (Fig. 2), since it was by means of the back-pressure resulting from this flow

that the instant of contacting the melt surface by the capillary could be detected.

When temperature equilibrium was reached inside the melt, the supporting mechanism to which the bubble tip was fastened was lowered to its rest position on the central platform of the pipe stand. The crucible support inside the furnace was next raised by means of the plunger (28) shown in Fig. 1. It was adjusted so that the end of the capillary tip would not be more than several millimeters above the level of the melt in the crucible. The tip was then lowered by the micrometer screw (4). Each complete turn of the screw lowered the tip  $\frac{1}{32}$  inch. The surface level was located by watching the levels of the manometer fluid during this process of lowering the tip very gradually, since as soon as the surface was contacted by the tip, the pressure in the nitrogen system would increase rapidly. Before making any further change in the level of the tip, the readings on the micrometer dial (3) and vertical scale (7) were noted.

By submerging the tip it is possible to minimize errors due to the thermal gradients which would reach a maximum near the surface of the melt; hence following location of the surface of the melt, the capillary tip was lowered a definitely measured distance to obtain a known depth of submergence. The small outside diameter of the platinum alloy capillary tip (approximately 2 mm.) and the small depth of submergence (1-4 mm.) resulted in a very small displacement of molten salt and thus a negligibly small change in the surface level of the melt in the crucible. These changes were neglected in the terms of equation 1 involving the quantity,  $h$ .

The apparatus was tested before being used on molten salts by making measurements at ordinary temperatures on liquids whose surface tension values have been determined precisely. Satisfactory agreement with accepted values was obtained in these experiments.

## Results

The results of the surface tension measurements on the salt mixtures of the potassium chloride-barium chloride system are arranged in Table I. Values of the surface tensions of these melts were plotted *versus* temperature. From the resulting straight lines values were interpolated for the surface tension at 800° for each composition. These values are shown graphically in Fig. 3. Values

of the temperature coefficients of surface tension obtained from these lines are presented in Table II.

TABLE II  
TEMPERATURE COEFFICIENTS OF SURFACE TENSION

BaCl <sub>2</sub> mole, %	$\gamma_t = \gamma_{800^\circ} - k(t - 800^\circ)$		BaCl <sub>2</sub> mole, %	$\gamma_t = \gamma_{800^\circ} - k(t - 800^\circ)$	
	$\gamma_{800^\circ}$ (dynes/cm.)	$-k$ (dynes/cm. per °C.)		$\gamma_{800^\circ}$ (dynes/cm.)	$-k$ (dynes/cm. per °C.)
0.0	96.2	0.072	37.3	114.3	0.061
3.9	98.4	.078	42.3	117.0	.044
8.4	101.7	.079	47.7	121.5	.066
13.5	102.8	.071	62.3	133.0	.077
24.4	108.9	.060	82.1	144.2 <sup>a</sup>	.076
29.4	111.0	.064	100.0	162.6 <sup>a</sup>	.078
34.0	112.8	.061			

<sup>a</sup> Extrapolated values.

### Discussion of Results

The consistency of the results obtained in this investigation gives confidence in their accuracy. The fact that the curves of surface tension *versus* temperature show a linear decrease with increasing temperature is in accord with the generally observed relationship between these variables. Furthermore, the measurements made on the pure salts gave values which agree with those of Jaeger<sup>8</sup> for potassium chloride and of Motylewski<sup>9</sup> for barium chloride. The termination of the curve of surface tension *versus* composition at 62.3 mole per cent. barium chloride is due to the higher melting points of the 82.1 mole per cent. mixture and of pure barium chloride.

The values for the temperature coefficient of surface tension do not show a simple variation with composition. There is considerable scatter in the plot of this quantity *versus* composition which makes the interpretation of this variation uncertain.

(8) P. M. Jaeger, *Z. anorg. Chem.*, **101**, 1 (1917).

(9) S. Motylewski, *ibid.*, **38**, 410 (1904).

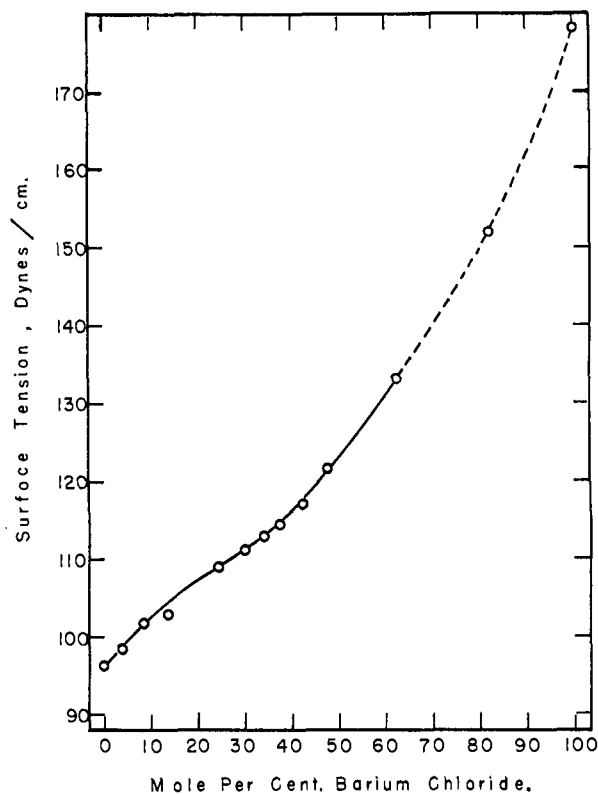

Fig. 3.—Surface tensions of KCl-BaCl<sub>2</sub> mixtures at 800°.

**Acknowledgment.**—The authors wish to acknowledge with gratitude the financial support given to this work by The Dow Chemical Company of Midland, Michigan. They wish also to acknowledge the helpful suggestions given by Professor T. F. Young of the University of Chicago and by Dr. James S. Machin of the Illinois State Geological Survey, Urbana, Illinois.

BLOOMINGTON, INDIANA

[CONTRIBUTION FROM THE DEPARTMENT OF CHEMISTRY, WAYNE UNIVERSITY]

## The Orthobaric Surface Tensions and Thermodynamic Properties of the Liquid Surfaces of a Series of 1-Alkenes, C<sub>6</sub> to C<sub>16</sub>, and of *n*-Decylcyclopentane, *n*-Decylcyclohexane and *n*-Decylbenzene

BY JOSEPH J. JASPER AND E. ROBERT KERR

RECEIVED JANUARY 4, 1954

This is the second of a series of three papers on surface tension measurements of hydrocarbons briefly describing the procedure for measuring orthobarically the surface tensions of a series of 1-alkenes and of *n*-decylcyclopentane, *n*-decylcyclohexane and *n*-decylbenzene. Surface tension-temperature data are presented in tables together with the constants of the least squares equations which relate the variables. From these data the entropies, enthalpies and latent heats of the liquid surfaces were calculated and tabulated in the tables.

The surface tension, which is the resultant of a differential attraction across a liquid-vapor interface, has proved to be an important and convenient index for comparing the magnitude of other physico-chemical properties of pure liquids which depend upon intermolecular attraction. It is a measure of the free energy of formation of unit area of the surface and from its application in the two-dimensional forms of the fundamental thermody-

amic equations<sup>1</sup> it is possible to determine the magnitude of the thermodynamic properties which are of such importance in the study of the nature of liquid surfaces. In recent years the purely theoretical concepts related to the surface properties of liquids now find their implementation in many technological processes to a most unexpected de-

(1) W. D. Harkins, "The Physical Chemistry of Surface Films," Reinhold Publ. Corp., New York, N. Y., 1952, Chap. 1 and 2.